

Referring both factory manuals (see the screenshots below) - R32 GTR heaters AND SENSOR get ground from pin 50. R33 GTR heaters AND SENSOR get ground from pin 115.

On R32 GTR ecu pin 115 is not connected. On R33 GTR ecu pin 115 provides heater ground. So to provide this GND using the R32 ECU we simply need to bridge pin 50 to 115 with a wire link.

B3 ECCS (Electronically Concentrated Engine Control System)

6. Sensor System Inspection (Cont'd)

6-7 EXHAUST GAS SENSOR SYSTEM INSPECTION

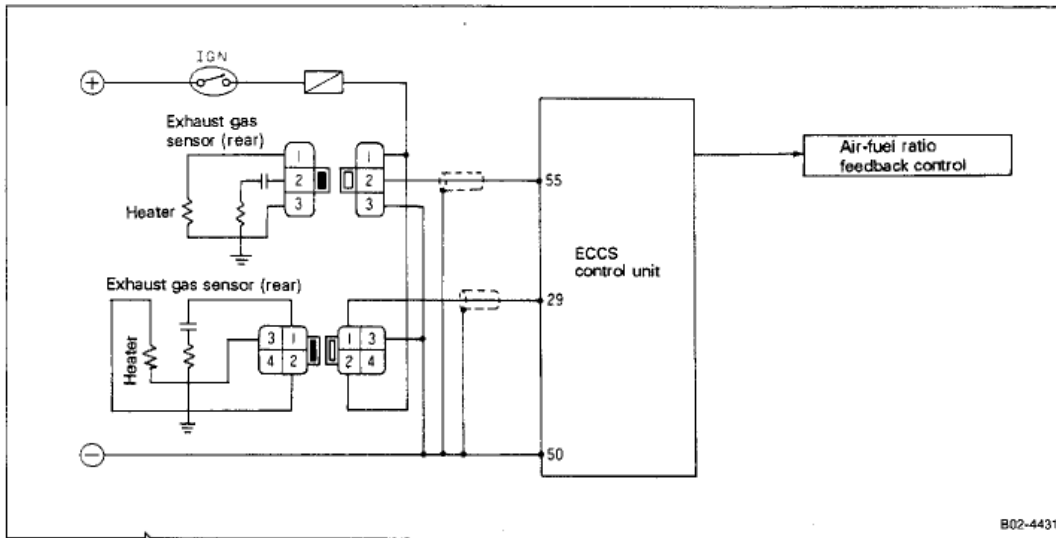

Cylinder, exhaust gas sensor, CONSULT (DATA MONITOR) display

Cylinder No.	Exhaust gas sensor	ECCS C/U terminal number	CONSULT (DATA MONITOR) display
No. 1, 2, 3, cylinders	Exhaust gas sensor (Front)	ECCS C/U terminal (29)	EXH GAS SEN-R
No. 4, 5, 6 cylinders	Exhaust gas sensor (Rear)	ECCS C/U terminal (55)	EXH GAS SEN

Figure 2 - R32 O2 Sensors

O₂ SENSOR HEATER SYSTEM

SYSTEM FAULT DIAGNOSIS

RB26DETT ENGINE

9. O₂ SENSOR HEATER SYSTEM CONTROL CIRCUIT DIAGRAM RB26DETT ENGINE

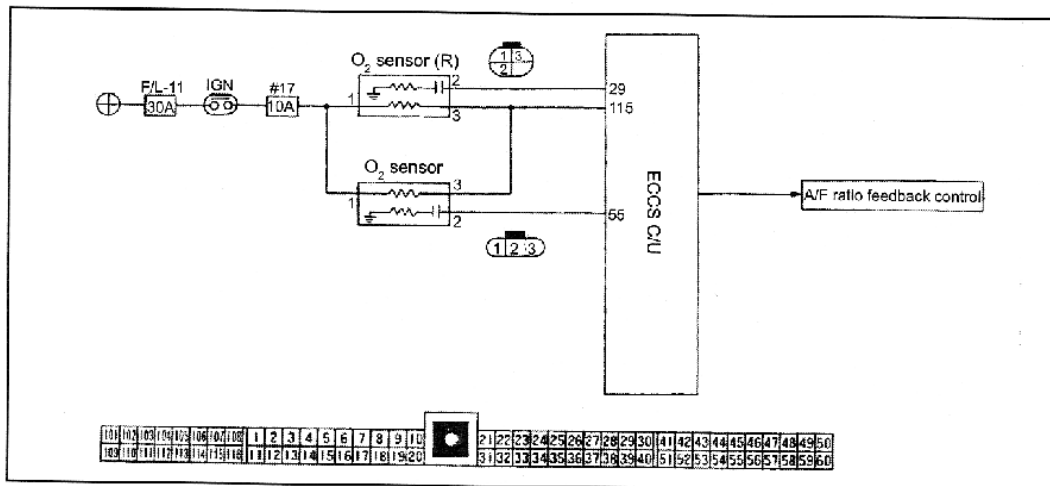

Figure 3 - R33 O2 Sensors